

# WHITWORTH AGR-PUD (SOUTH) - PLAT FOUR

BEING ALL OF TRACTS 88 THROUGH 90, INCLUSIVE, AND A PORTION OF TRACTS 78 THROUGH 82, INCLUSIVE, TRACT 87, TRACT 91, AND A PORTION OF ROAD, DYKE AND DITCH RESERVATIONS 30 FEET IN WIDTH, WHICH ABUT SAID TRACTS, ALL LYING WITHIN BLOCK 60, PALM BEACH FARMS CO. PLAT NO. 3, ACCORDING TO THE PLAT THEREOF, AS RECORDED IN PLAT BOOK 2, PAGE 45, OF THE PUBLIC RECORDS OF PALM BEACH COUNTY, FLORIDA, LYING IN SECTION 31, TOWNSHIP 45 SOUTH, RANGE 42 EAST AND SECTION 6, TOWNSHIP 46 SOUTH, RANGE 42 EAST

SHEET 9 OF 10

60

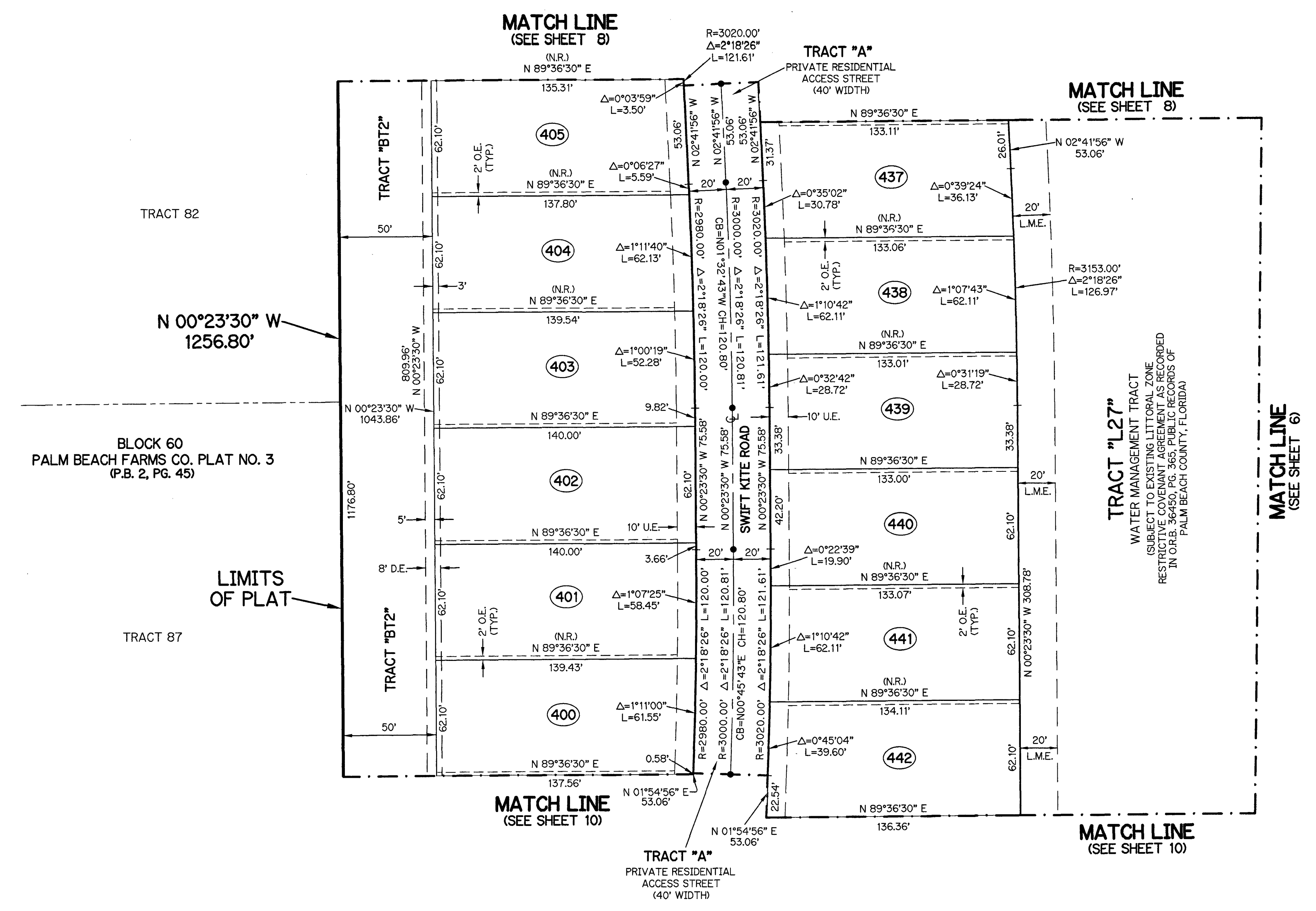
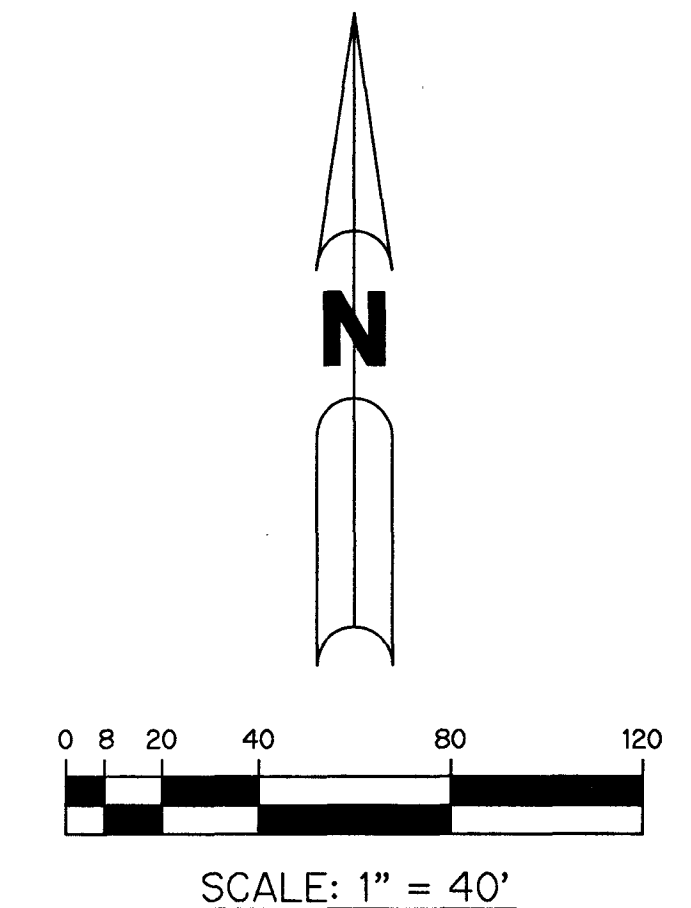

- LEGEND:**
- ▲ - SET PERMANENT REFERENCE MONUMENT 5/8" IRON ROD 1.5' IN LENGTH 1.4" CAP STAMPED PRM L.B. #7741
  - △ - FOUND PERMANENT REFERENCE MONUMENT 5/8" IRON ROD 1.5' IN LENGTH 1.4" CAP STAMPED PRM L.B. #7741
  - - SET PERMANENT REFERENCE MONUMENT 4"x4" CONCRETE MONUMENT WITH 1.5" DISK STAMPED PRM L.B. #7741
  - - FOUND PERMANENT REFERENCE MONUMENT 4"x4" CONCRETE MONUMENT WITH 1.5" DISK STAMPED PRM L.B. #7741
  - - SET PERMANENT CONTROL POINT NAIL WITH 1.25" DISK STAMPED PCP L.B. #7741
  - - FOUND PERMANENT CONTROL POINT NAIL WITH 1.25" DISK STAMPED PCP L.B. #7741
  - AGR - AGRICULTURAL
  - Δ - DELTA ANGLE
  - B.T. - BUFFER TRACT
  - BLK - BLOCK
  - CB - CHORD BEARING
  - CH - CHORD DISTANCE
  - CL - CENTERLINE
  - DB - DEED BOOK
  - DE - PRIVATE DRAINAGE EASEMENT
  - ESMT - EASEMENT
  - F.P.L. - FLORIDA POWER & LIGHT
  - L - ARC LENGTH
  - L.A.E. - LIMITED ACCESS EASEMENT
  - LB - LICENSED BUSINESS
  - L.M.A.E. - LAKE MAINTENANCE ACCESS EASEMENT
  - L.M.E. - LAKE MAINTENANCE EASEMENT
  - L.W.D.D. - LAKE WORTH DRAINAGE DISTRICT
  - N.R. - NOT RADIAL
  - N.R.T.R. - NOT RADIAL TO REAR LINE
  - N.T. - NON-TANGENT
  - N.T.S. - NOT TO SCALE
  - O.R.B. - OFFICIAL RECORD BOOK
  - O.E. - MAINTENANCE & ROOF OVERHANG EASEMENT
  - P.B.C.O. - PALM BEACH COUNTY
  - P.B.C.U.E. - PALM BEACH COUNTY UTILITY EASEMENT
  - P.B. - PLAT BOOK
  - P.C. - POINT OF CURVATURE
  - P.C.C. - POINT OF COMPOUND CURVATURE
  - P.C.P. - PERMANENT CONTROL POINT
  - P.D.E. - PUBLIC DRAINAGE EASEMENT
  - PG. - PAGE
  - PGS. - PAGES
  - P.O.B. - POINT OF BEGINNING
  - P.N.R.I. - POINT OF NON-RADIAL INTERSECTION
  - P.N.T.I. - POINT OF NON-TANGENT INTERSECTION
  - P.O.C. - POINT OF COMMENCEMENT
  - P.O.I. - POINT OF INTERSECTION
  - P.R.C. - POINT OF REVERSE CURVATURE
  - P.R.I. - POINT OF RADIAL INTERSECTION
  - P.S.M. - PROFESSIONAL SURVEYOR AND MAPPER
  - P.T. - POINT OF TANGENCY
  - PUD - PLANNED UNIT DEVELOPMENT
  - R - RADIUS
  - RAD - RADIAL
  - R/W - RIGHT-OF-WAY
  - R.D. & D. - ROAD, DYKE AND DITCH RESERVATION
  - S.I.R.C. - SET 5/8" IRON ROD & CAP STAMPED "PRM LB7741"
  - SN&D - SET MAGNETIC NAIL & DISK STAMPED "PRM LB7741"
  - S.T. - SURVEY TIE
  - TYP. - TYPICAL
  - U.E. - UTILITY EASEMENT
  - N=780000.00 - STATE PLANE COORDINATE VALUE
  - E=930000.00

BLOCK 60  
PALM BEACH FARMS CO. PLAT NO. 3  
(P.B. 2, PG. 45)

LIMITS  
OF PLAT

**NOTES:**  
 COORDINATES SHOWN ARE GRID COORDINATES DATUM = NAD 83 (1990 ADJUSTMENT)  
 ZONE = FLORIDA EAST ZONE  
 LINEAR UNIT = U.S. SURVEY FEET  
 COORDINATE SYSTEM = 1983 STATE PLANE TRANSVERSE MERCATOR PROJECTION  
 ALL DISTANCES ARE GROUND UNLESS OTHERWISE NOTED  
 SCALE FACTOR = 1.00002026  
 PLAT BEARING = GRID BEARING  
 GROUND DISTANCE X SCALE FACTOR = GRID DISTANCE

THIS INSTRUMENT WAS PREPARED BY  
 PERRY C. WHITE, P.S.M. 4213, STATE OF FLORIDA  
 SAND & HILLS SURVEYING, INC.  
 6675 E. CALUMET CIRCLE  
 LAKE WORTH, FLORIDA 33467  
 LB-7741

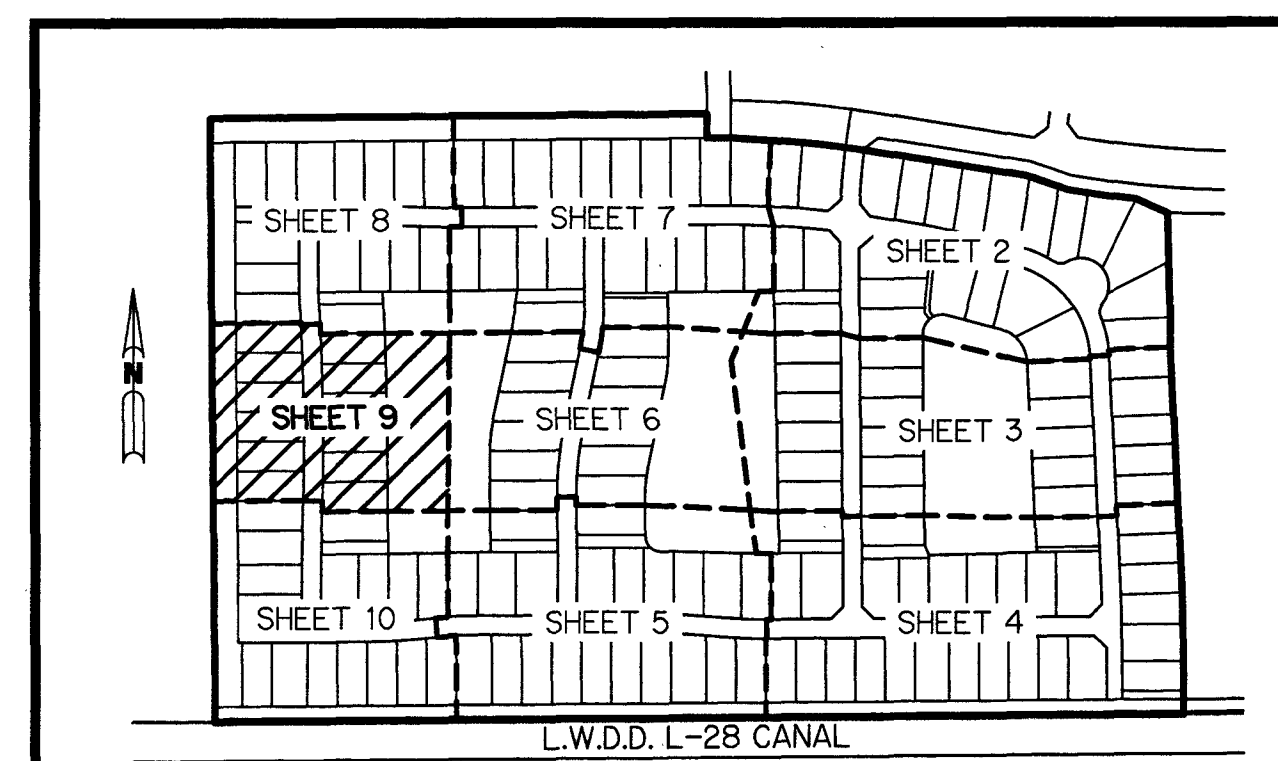

**KEY MAP**  
N.T.S.

WHITWORTH AGR-PUD (SOUTH) - PLAT FOUR

SH0362

SHEET 9 OF 10